



# VIXEN

VMC110L



<b>PREFACE</b>	Thank you very much for your purchase of a Vixen astronomical telescope	
This manual applies to the VMC110L Telescope. You may occasionally find descriptions in the text not relevant to your particular model. Read the instructions for your mount along with this manual if you purchased the telescope as a complete package.		
<b>WARNING!</b>	Never look directly at the sun with the telescope or its finder or guide scope. Permanent and irreversible eye damage may result.	
<b>CAUTION</b>	Do not leave the optical tube uncapped in the daytime. Sunlight passing through the telescope or finder scope may cause a fire.	
	Do not use the product while moving or walking, injuries could result from a collision with objects or from stumbling or falling.	
	Keep small caps, plastic bags, or plastic packing materials away from children. These may cause a danger of swallowing or suffocation.	
	Do not use the product in a wet environment and do not handle with wet hands.	
<b>HANDLING AND STORAGE</b>		
	Do not leave the product inside a car in bright sunshine or in other hot places. Keep any strong heat sources away from the product.	
	When cleaning, do not use solvents such as paint thinner or similar products.	
	Do not expose the product to rain, water, dirt or sand.	
	Avoid touching any lens or mirror surfaces directly with your hands. In case a lens or mirror becomes dirty with fingerprints or general smears, gently wipe it using a commercially available lens cleaner and a lens cleaning paper or cloth, or consult your local Vixen dealer.	
	Blow off dust on lenses using a commercially available blower brush. Do not use compressed air.	
	For storage, keep the product in a dry place and do not expose to direct sunlight.	
<b>SETTING UP THE TELESCOPE-</b> Refer to your mount instructions along with this manual.		
Attaching the Telescope to your Mount	Example: Attaching to the SKYPOD	Example: Attaching to the PORTA Mount
(1) Loosen both the dovetail-plate lock screw and safety screw until the tips of these screws no longer extended into the inner part of the dovetail block. Slide the dovetail-mounted scope into the dovetail mounting block of the mount and tighten the dovetail lock screw (centered on the notch) onto the dovetail tube plate until snug.		
(2) First tighten the dovetail lock screw, and then tighten the small chrome safety screw onto the dovetail mounting block until snug.		

### Example: Attaching to the GP2 Mount

\*Change the position of the dovetail tube plate on the VMC110L optical tube with the supplied Allen wrench. If you attach it onto a Vixen mount other than the SKYPOD and PORTA, remove the dovetail tube plate from the side of the VMC110L optical tube.

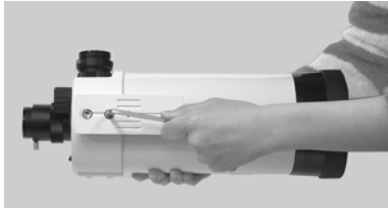

\*Attach the dovetail tube plate to the bottom of the VMC110L optical tube as shown in the figure.

\*Loosen both the dovetail-plate lock screw and safety screw until the tips of these screws no longer extend into the inner part of the dovetail block. Slide the dovetail-mounted scope into the dovetail mounting block of the mount and tighten the dovetail lock screw (centered on the notch) onto the dovetail tube plate until snug.

\***First tighten** the dovetail lock screw, and then tighten the small chrome safety screw onto the dovetail mounting block until snug.

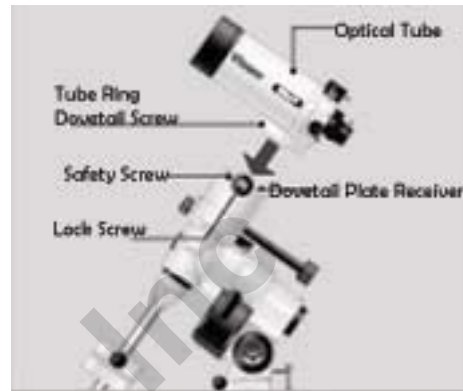

### ATTACHING THE FINDER SCOPE

Loosen the chrome finder bracket lock screw on the telescope.



Attach the finder scope as shown in the figure. Tighten the finder bracket lock screw securely.



## ACCESSORY CHART

### Visual Configuration



### Magnification of the Telescope

When using an eyepiece with short focal length (small number in millimeters), the image will be dim and the range of sharp focus will be small. The image will be harder to see so begin with an eyepiece with long focal length. Dividing the focal length of the telescope by the focal length of the eyepiece gives the magnification.

Example: Calculating the eyepiece magnification of a telescope with 1035mm focal length.

Eyepiece	Focal length of telescope	Focal length of eyepiece	Magnification
PL20mm	1035mm	20mm	52x
PL 5mm	1035mm	5mm	173x

## PHOTOGRAPHIC CONFIGURATION

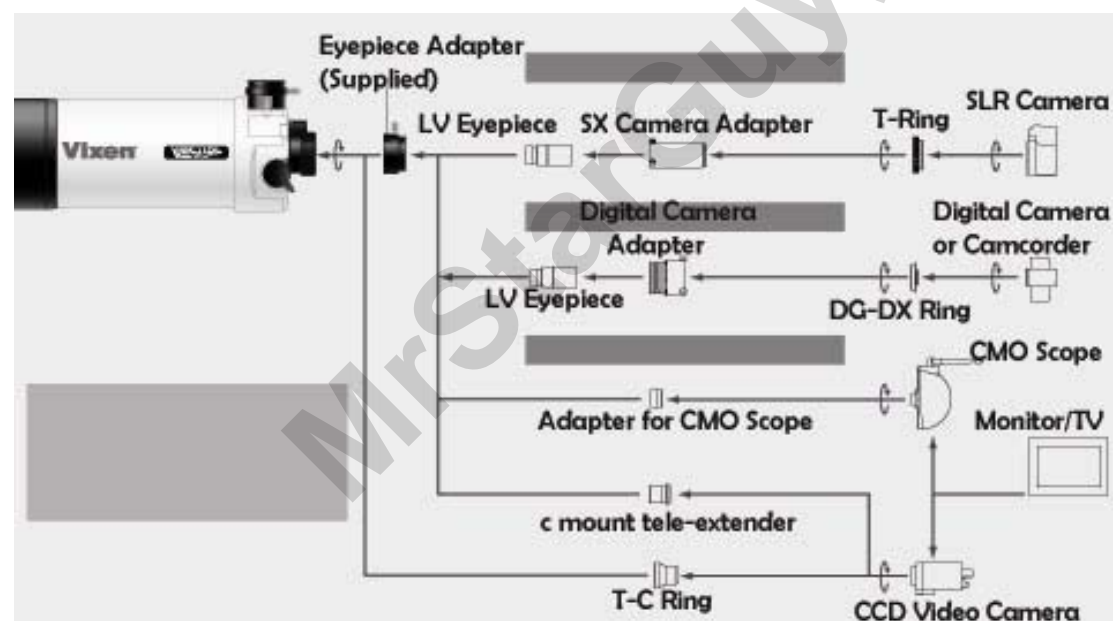

Photography with an SLR Camera

Photography with a Digital Camera

Photography with CMOScope or CCD Video Camera

Some of optional accessories shown in this chart will be needed if you take pictures with SLR camera, digital camera or CCD video camera.

## SPECIFICATIONS

Optical System	VMC (Vixen's original Maksutov-Cassegrain)
Primary mirror	Multi-coated precision spherical mirror
Effective aperture	110mm
Focal length (focal ratio)	1035mm (f/9.4)
Resolving power	1.05 arc seconds
Limiting magnitude	12,0
Light gathering power	247x
Finder	Dot finder (no magnifying power)
Dimensions	Outer diameter: 125mm, length: 360mm
Weight	2.1kgs
Accessories	Eyepiece PL-25mm (31.7mm), Allen wrench

## RE-COLLIMATION

Please contact a Vixen dealer in your area for repair if your Vixen telescope is out of collimation.

Collimated Properly

Mis-Collimated

In Focus

Out of Focus

In Focus

Out of Focus

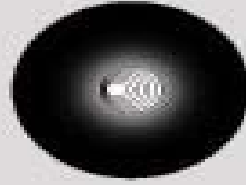
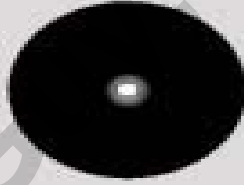
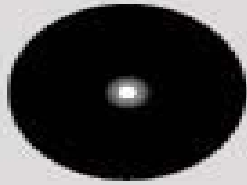

# VMC110L OPTICAL TUBE UNIT

## HOW TO COLLIMATE THE OPTICAL AXIS

There are three pairs of the collimation adjustment screws (A, B & C) on the back frame of the optical tube as illustrated below (Fig. 1). The screws B and C are covered with black rubber caps. The screws A are behind the flip mirror lever. When using the screws A, remove the flip mirror lever.

Each pair of the collimation adjustment screws consists of a pushing screw and a pulling screw. In the Fig. 1, the pushing screw is colored yellow and the pulling screw is colored green. These screws are glued. Before using these screws to make collimation adjustments, dissolve the adhesive agent with thinner or alcohol, otherwise heads of the screws may be broken with a screw driver.

Fig. 1

Fig. 2

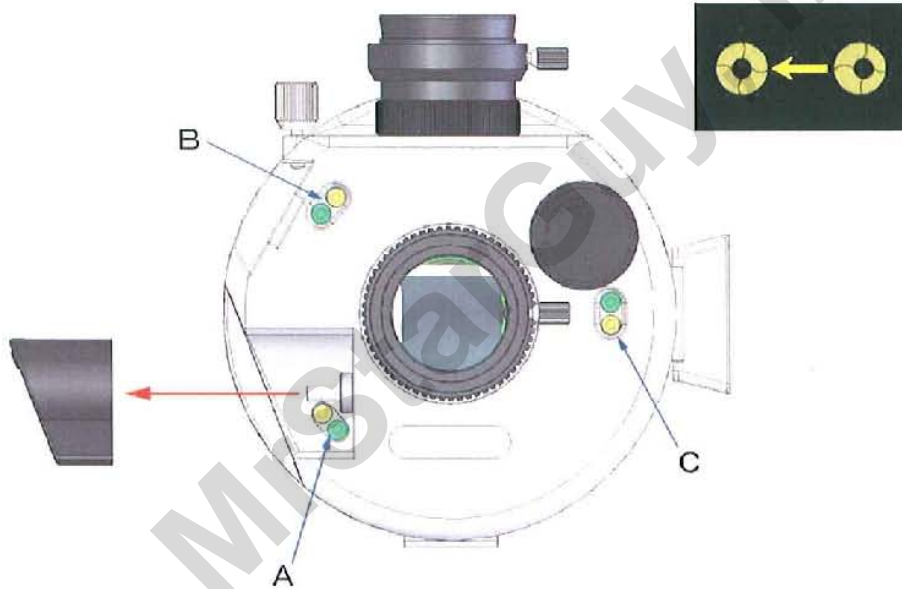

When making a star image out of focus, you can see a dark silhouette of the secondary mirror in the field of view as shown in the Fig. 2. If the dark silhouette of the secondary mirror is not centered, collimation adjustments will be needed. To center the dark silhouette, tighten the pushing screw toward which the dark silhouette is out of center. If the pushing screw cannot be tightened any more, loosen the pulling screw once before tightening the pushing screw. It is advisable to start with a low-power eyepiece, and then use a high-power eyepiece in order to achieve good collimation adjustments.